

### Related Styles

Line Slot: Rapid Rivers II LS Shrt	State: Production	Season: F24
Merchandise Division: Sportswear	Merchandise Collection: Outdoor	Product Class: Woven Tops L/S
Designer: Sara.Allegre	Developer: cwestgate	LO Developer: raman.garg
Fit Engineer: alicehan		Sourcing Manager: melissa.gallagher



Design:	F4MS155205	Sample LO:	Production LO:	India			
Style	Material Style	Style Description	Pattern	Base Size	Size Scale	Fit	SMU Type
AS7968	1552053	Rapid Rivers™ II Long Sleeve Shirt	M14S7113	2X	1X - 6X	Regular	N/A

Style	Material Style	Style Description	Design	Pattern	Base Size	Size Scale	Sample LO	Production LO
AT7968	1552054	Rapid Rivers™ II Long Sleeve Shirt	F4MS155205	M14T7113	2XT	LT - 5XT		India
AM7968	1552051	Rapid Rivers™ II Long Sleeve Shirt	F4MS155205	M18M7215	M	S - XXL		India

This is confidential and proprietary information of Columbia Sportswear Company. You agree that you will not disclose this information to any third party or use it for any purpose other than on behalf of Columbia. You have no right to use Columbia's name or any of its trademarks, trade names, copyrights, patents, designs or other intellectual property except as set forth in writing by Columbia.









### Color BOM

Line Slot: Rapid Rivers II LS Shrt	State: Production	Season: F24
Merchandise Division: Sportswear	Merchandise Collection: Outdoor	Product Class: Woven Tops L/S
Designer: Sara.Allegre	Developer: cwestgate	LO Developer: raman.garg
Fit Engineer: alicehan		Sourcing Manager: melissa.gallagher
Design: F4MS155205	Sample LO:	Production LO: India
Style Material Style	Style Description Pattern	Base Size Size Scale Fit SMU Type
AS7968 1552053	Rapid Rivers™ II M14S7113 Long Sleeve Shirt	2X 1X - 6X Regular N/A



Component	Details	Placement	Usage	Width	Marker Width	008-Black Everyday Gingham	396-Stone Green Oxford	434-Mtn Blue Everyday Gingham	471-Collegiate Navy Everyday Gingham	472-Collegiate Navy Everyday Gingham
<b>SAP Material Code</b>						155205100 8	155205139 6	155205143 4	155205147 1	155205147 2
						155205300 8	155205339 6	155205343 4	155205347 1	155205347 2
						155205400 8	155205439 6	155205443 4	155205447 1	155205447 2
<b>SMU Accounts</b>						N/A	N/A	N/A	N/A	N/A
Shell 1	108372 S21 M SW YD on 092290 AP 9387 Poplin 97% Cotton, 3% Elastane 120 X 64 40 X 40 LYCRA MaterialCoatingNone MaterialLaminateNone 120.0 g/m2 Yarn Dye NA	Everyday Gingham	2.211 yd	56.0	55.984	black	None	mountain blue	collegiate navy	collegiate navy2
Alt Shell 1A	121231 F23 M SW YD on 121321 (basketweave version of 092290) AP 11102 Basketweave 97% Cotton, 3% Elastane 120 x 74 40 x 40 lycra MaterialFinishNone, Yarn Dyed MaterialCoatingNone MaterialLaminateNone 120.0 g/m2 Yarn Dye NA	Oxford	2.201 yd	54.0	55.984	None	stone green	None	None	None
Interfacing 1	011952 Interlining Non-Woven Fusible Light Weight for Garment Wash Interlining 100% Polyester 0.0 g/m2		0.185 yd	60.0	60	White	White	White	White	White
Button 1	097383 20L DEBOSSSED COLUMBIA TWO TONE (LIKE 001601) LOW PROFILE Plastic BUTTON (SHAPE LIKE 056644)	Keep for C/O	13 ea	0.0	0	None	None	None	None	None

### Color BOM

Line Slot: Rapid Rivers II LS Shrt  
 Merchandise Division: Sportswear  
 Designer: Sara.Allegre  
 Fit Engineer: alicehan

Merchandise Collection: Outdoor  
 Developer: cwestgate

State: Production  
 Product Class: Woven Tops L/S  
 LO Developer: raman.garg

Season: F24  
 Sourcing Manager: melissa.gallagher



Design: F4MS155205  
 Style: Material Style  
 AS7968

Sample LO:  
 Style Description: Rapid Rivers™ II Long Sleeve Shirt  
 Pattern: M14S7113

Production LO: India  
 Base Size: 2X  
 Size Scale: 1X - 6X

Fit: Regular  
 SMU Type: N/A

Component	Details	Placement	Usage	Width	Marker Width	008-Black Everyday Gingham	396-Stone Green Oxford	434-Mtn Blue Everyday Gingham	471-Collegiate Navy Everyday Gingham	472-Collegiate Navy Everyday Gingham
<b>SAP Material Code</b>						155205100 8	155205139 6	155205143 4	155205147 1	155205147 2
						155205300 8	155205339 6	155205343 4	155205347 1	155205347 2
						155205400 8	155205439 6	155205443 4	155205447 1	155205447 2
Alt Button 1	098148 20L DEBOSSSED COLUMBIA DARK HORN/LIGHT HORN (NO DTM) LOW PROFILE BUTTON (LIKE 056644)	New F22 CW's	13 ea	0.0	0	Dark Horn	Dark Horn	Light Horn	Dark Horn	Light Horn
Button 2	097381 14L DEBOSSSED COLUMBIA TWO TONE (LIKE 001601) LOW PROFILE BUTTON (SHAPE LIKE 056644)	Keep for C/O	2 ea	0.0	0	None	None	None	None	None
Alt Button 2	098146 14L DEBOSSSED COLUMBIA DARK HORN/LIGHT HORN (NO DTM) LOW PROFILE BUTTON (LIKE 056644)	New F22 CW's	2 ea	0.0	0	Dark Horn	Dark Horn	Light Horn	Dark Horn	Light Horn
Label Logo 1	077256 35mm Gem Columbia Flat Woven Label with starch		1 ea	0.0	0	Grill, Columbia Grey	Black, White	Columbia Grey, Grill	Columbia Grey, Grill	Columbia Grey, Grill
Thread 1	008214 Coats ASTRA Spun Polyester Tex 27 40/2		213 meter	0.0	0	White	Stone Green	White	White	Collegiate Navy
Thread 2	008214 Coats ASTRA Spun Polyester Tex 27 40/2		10 meter	0.0	0	White	Stone Green	White	White	Collegiate Navy
Webbing and Tape 1	033416 3/8 in. Spun Poly Herringbone Tape 1 clr FOR SUN HOD Choose from Color Card		0.083 yd	0.0	0	Black	Stone Green	Mountain Blue	Collegiate Navy	Collegiate Navy
Label 1	059200 40mm CSC International Size Extended Woven ECO Loop Label for use with Hanger Loop		1 ea	0.0	0	White, Columbia Grey, Compass Blue	White, Columbia Grey, Compass Blue	White, Columbia Grey, Compass Blue	White, Columbia Grey, Compass Blue	White, Columbia Grey, Compass Blue

### Color BOM

Line Slot: Rapid Rivers II LS Shrt	State: Production	Season: F24
Merchandise Division: Sportswear	Merchandise Collection: Outdoor	Product Class: Woven Tops L/S
Designer: Sara.Allegre	Developer: cwestgate	LO Developer: raman.garg
Fit Engineer: alicehan	Sourcing Manager: melissa.gallagher	
Design: F4MS155205	Sample LO:	Production LO: India
Style AS7968	Material Style 1552053	Style Description Pattern Rapid Rivers™ II Long Sleeve Shirt
	Base Size 2X	Size Scale 1X - 6X
		Fit Regular
		SMU Type N/A



Component	Details	Placement	Usage	Width	Marker Width	008-Black Everyday Gingham	396-Stone Green Oxford	434-Mtn Blue Everyday Gingham	471-Collegiate Navy Everyday Gingham	472-Collegiate Navy Everyday Gingham
<b>SAP Material Code</b>						155205100 8	155205139 6	155205143 4	155205147 1	155205147 2
						155205300 8	155205339 6	155205343 4	155205347 1	155205347 2
						155205400 8	155205439 6	155205443 4	155205447 1	155205447 2
Label 2	006564 33mm Care Content ECO Booklet Fold label with fully translated country of origin WHT/BLK for most, BLK/WHT for Titanium only, GRY/BLK is for Garment DYE ONLY		1 ea	0.0	0	White, Black	White, Black	White, Black	White, Black	White, Black
Hangtag Package Part	121612 MSRP/UPC with RFID Specs for MSRP. Please refer to VAS specs for any exceptions. MSRP required on all product shipping to the US.		1 ea	0.0	0	Artwork	Artwork	Artwork	Artwork	Artwork
Hangtag Package Part	097305 Columbia No Tech Hangtag		1 ea	0.0	0	Artwork	Artwork	Artwork	Artwork	Artwork
Hangtag Package Part	126967 Regular Fit Swing Tag		1 ea	0.0	0	Artwork	Artwork	Artwork	Artwork	Artwork
Packaging 1	064194 Outer Carton for costing purpose only		1 ea	0.0	0	Stock	Stock	Stock	Stock	Stock
Packaging 2	980001 Polybag See Standard CCS 4200 for specifications		1 ea	0.0	0	Stock	Stock	Stock	Stock	Stock
Packaging 3	980010 UPC Bag Sticker Generic (MHW/Columbia) See CCS4400/ 4401 and MHW4402 for Mt Hardwear for instructions		1 ea	0.0	0	Artwork	Artwork	Artwork	Artwork	Artwork



### Color BOM

Line Slot: Rapid Rivers II LS Shrt	State: Production	Season: F24
Merchandise Division: Sportswear	Merchandise Collection: Outdoor	Product Class: Woven Tops L/S
Designer: Sara.Allegre	Developer: cwestgate	LO Developer: raman.garg
Fit Engineer: alicehan		Sourcing Manager: melissa.gallagher
Design: F4MS155205	Sample LO:	Production LO: India
Style Material Style	Style Description	Pattern
AS7968	1552053	Rapid Rivers™ II Long Sleeve Shirt
	Base Size	Size Scale
	2X	1X - 6X
	Fit	SMU Type
	Regular	N/A



Component	Details	Placement	Usage	Width	Marker Width	482-Dark Mountain Oxford	681-Spice Oxford	699-Sail Red Everyday Gingham	861-Sunstone Everyday Gingham
<b>SAP Material Code</b>						1552051482	1552051681	1552051699	1552051861
						1552053482	1552053681	1552053699	1552053861
						1552054482	1552054681	1552054699	1552054861
<b>SMU Accounts</b>						N/A	N/A	N/A	N/A
Shell 1	108372 S21 M SW YD on 092290 AP 9387 Poplin 97% Cotton, 3% Elastane 120 X 64 40 X 40 LYCRA MaterialCoatingNone MaterialLaminateNone 120.0 g/m2 Yarn Dye NA	Everyday Gingham	2.211 yd	56.0	55.984	None	None	sail red	sunstone
Alt Shell 1A	121231 F23 M SW YD on 121321 (basketweave version of 092290) AP 11102 Basketweave 97% Cotton, 3% Elastane 120 x 74 40 x 40 lycra MaterialFinishNone, Yarn Dyed MaterialCoatingNone MaterialLaminateNone 120.0 g/m2 Yarn Dye NA	Oxford	2.201 yd	54.0	55.984	dark mountain	spice	None	None
Interfacing 1	011952 Interlining Non-Woven Fusible Light Weight for Garment Wash Interlining 100% Polyester 0.0 g/m2		0.185 yd	60.0	60	White	White	White	White
Button 1	097383 20L DEBOSSSED COLUMBIA TWO TONE (LIKE 001601) LOW PROFILE Plastic BUTTON (SHAPE LIKE 056644)	Keep for C/O	13 ea	0.0	0	None	None	None	None
Alt Button 1	098148 20L DEBOSSSED COLUMBIA DARK HORN/LIGHT HORN (NO DTM) LOW PROFILE BUTTON (LIKE 056644)	New F22 CW's	13 ea	0.0	0	Light Horn	Light Horn	Light Horn	Dark Horn

### Color BOM

Line Slot: Rapid Rivers II LS Shrt	State: Production	Season: F24
Merchandise Division: Sportswear	Merchandise Collection: Outdoor	Product Class: Woven Tops L/S
Designer: Sara.Allegre	Developer: cwestgate	LO Developer: raman.garg
Fit Engineer: alicehan		Sourcing Manager: melissa.gallagher
Design: F4MS155205	Sample LO:	Production LO: India
Style Material Style	Style Description	Pattern
AS7968	1552053	Rapid Rivers™ II Long Sleeve Shirt
	Base Size	Size Scale
	2X	1X - 6X
	Fit	SMU Type
	Regular	N/A



Component	Details	Placement	Usage	Width	Marker Width	482-Dark Mountain Oxford	681-Spice Oxford	699-Sail Red Everyday Gingham	861-Sunstone Everyday Gingham
<b>SAP Material Code</b>						1552051482	1552051681	1552051699	1552051861
						1552053482	1552053681	1552053699	1552053861
						1552054482	1552054681	1552054699	1552054861
Button 2	097381 14L DEBOSSSED COLUMBIA TWO TONE (LIKE 001601) LOW PROFILE BUTTON (SHAPE LIKE 056644)	Keep for C/O	2 ea	0.0	0	None	None	None	None
Alt Button 2	098146 14L DEBOSSSED COLUMBIA DARK HORN/LIGHT HORN (NO DTM) LOW PROFILE BUTTON (LIKE 056644)	New F22 CW's	2 ea	0.0	0	Light Horn	Light Horn	Light Horn	Dark Horn
Label Logo 1	077256 35mm Gem Columbia Flat Woven Label with starch		1 ea	0.0	0	Columbia Grey, Grill	Grill, Columbia Grey	Black, White	Black, White
Thread 1	008214 Coats ASTRA Spun Polyester Tex 27 40/2		213 meter	0.0	0	Dark Mountain	Spice	White	White
Thread 2	008214 Coats ASTRA Spun Polyester Tex 27 40/2		10 meter	0.0	0	Dark Mountain	Spice	White	White
Webbing and Tape 1	033416 3/8 in. Spun Poly Herringbone Tape 1 clr FOR SUN HOD Choose from Color Card		0.083 yd	0.0	0	Dark Mountain	Spice	Sail Red	Sunstone
Label 1	059200 40mm CSC International Size Extended Woven ECO Loop Label for use with Hanger Loop		1 ea	0.0	0	White, Columbia Grey, Compass Blue	White, Columbia Grey, Compass Blue	White, Columbia Grey, Compass Blue	White, Columbia Grey, Compass Blue
Label 2	006564 33mm Care Content ECO Booklet Fold label with fully translated country of origin WHT/BLK for most, BLK/WHT for Titanium only, GRY/BLK is for Garment DYE ONLY		1 ea	0.0	0	White, Black	White, Black	White, Black	White, Black
Hangtag Package Part	121612 MSRP/UPC with RFID Specs for MSRP. Please refer to VAS specs for any exceptions. MSRP required on all product shipping to the US.		1 ea	0.0	0	Artwork	Artwork	Artwork	Artwork
Hangtag Package Part	097305 Columbia No Tech Hangtag		1 ea	0.0	0	Artwork	Artwork	Artwork	Artwork

### Color BOM

Line Slot: Rapid Rivers II LS Shrt	State: Production	Season: F24
Merchandise Division: Sportswear	Merchandise Collection: Outdoor	Product Class: Woven Tops L/S
Designer: Sara.Allegre	Developer: cwestgate	LO Developer: raman.garg
Fit Engineer: alicehan		Sourcing Manager: melissa.gallagher
Design: F4MS155205	Sample LO:	Production LO: India
Style AS7968	Material Style 1552053	Style Description Pattern Rapid Rivers™ II Long Sleeve Shirt
	Base Size 2X	Size Scale 1X - 6X
		Fit Regular
		SMU Type N/A



Component	Details	Placement	Usage	Width	Marker Width	482-Dark Mountain Oxford	681-Spice Oxford	699-Sail Red Everyday Gingham	861-Sunstone Everyday Gingham
<b>SAP Material Code</b>						1552051482	1552051681	1552051699	1552051861
						1552053482	1552053681	1552053699	1552053861
						1552054482	1552054681	1552054699	1552054861
Hangtag Package Part	126967 Regular Fit Swing Tag		1 ea	0.0	0	Artwork	Artwork	Artwork	Artwork
Packaging 1	064194 Outer Carton for costing purpose only		1 ea	0.0	0	Stock	Stock	Stock	Stock
Packaging 2	980001 Polybag See Standard CCS 4200 for specifications		1 ea	0.0	0	Stock	Stock	Stock	Stock
Packaging 3	980010 UPC Bag Sticker Generic (MHW/Columbia) See CCS4400/ 4401 and MHW4402 for Mt Hardwear for instructions		1 ea	0.0	0	Artwork	Artwork	Artwork	Artwork

This is confidential and proprietary information of Columbia Sportswear Company. You agree that you will not disclose this information to any third party or use it for any purpose other than on behalf of Columbia. You have no right to use Columbia's name or any of its trademarks, trade names, copyrights, patents, designs or other intellectual property except as set forth in writing by Columbia.

## Colorless BOM

Line Slot: Rapid Rivers II LS Shrt      State: Production      Season: F24  
 Merchandise Division: Sportswear      Merchandise Collection: Outdoor      Product Class: Woven Tops L/S  
 Designer: Sara.Allegre      Developer: cwestgate      LO Developer: raman.garg      Sourcing Manager: melissa.gallagher

Fit Engineer: alicehan

Design: F4MS155205      Sample LO:      Production LO: India

Style	Material Style	Style Description	Pattern	Base Size	Size Scale	Fit	SMU Type
AS7968	1552053	Rapid Rivers™ II Long Sleeve Shirt	M14S7113	2X	1X - 6X	Regular	N/A



Component	Details	Placement	Usage	Width	Marker Width
<b>SAP Material Code</b>					
Shell 1	108372 S21 M SW YD on 092290 AP 9387 Poplin 97% Cotton, 3% Elastane 120 X 64 40 X 40 LYCRA MaterialCoatingNone MaterialLaminateNone 120.0 g/m2 Yarn Dye NA	Everyday Gingham	2.211 yd	56.0	55.984
Alt Shell 1A	121231 F23 M SW YD on 121321 (basketweave version of 092290) AP 11102 Basketweave 97% Cotton, 3% Elastane 120 x 74 40 x 40 lycra MaterialFinishNone, Yarn Dyed MaterialCoatingNone MaterialLaminateNone 120.0 g/m2 Yarn Dye NA	Oxford	2.201 yd	54.0	55.984
Interfacing 1	011952 Interlining Non-Woven Fusible Light Weight for Garment Wash Interlining 100% Polyester 0.0 g/m2		0.185 yd	60.0	60
Button 1	097383 20L DEBOSSSED COLUMBIA TWO TONE (LIKE 001601) LOW PROFILE Plastic BUTTON (SHAPE LIKE 056644)	Keep for C/O	13 ea	0.0	0
Alt Button 1	098148 20L DEBOSSSED COLUMBIA DARK HORN/LIGHT HORN (NO DTM) LOW PROFILE BUTTON (LIKE 056644)	New F22 CW's	13 ea	0.0	0
Button 2	097381 14L DEBOSSSED COLUMBIA TWO TONE (LIKE 001601) LOW PROFILE BUTTON (SHAPE LIKE 056644)	Keep for C/O	2 ea	0.0	0
Alt Button 2	098146 14L DEBOSSSED COLUMBIA DARK HORN/LIGHT HORN (NO DTM) LOW PROFILE BUTTON (LIKE 056644)	New F22 CW's	2 ea	0.0	0
Label Logo 1	077256 35mm Gem Columbia Flat Woven Label with starch		1 ea	0.0	0
Thread 1	008214 Coats ASTRA Spun Polyester Tex 27 40/2		213 meter	0.0	0
Thread 2	008214 Coats ASTRA Spun Polyester Tex 27 40/2		10 meter	0.0	0
Webbing and Tape 1	033416 3/8 in. Spun Poly Herringbone Tape 1 clr FOR SUN HOD Choose from Color Card		0.083 yd	0.0	0
Label 1	059200 40mm CSC International Size Extended Woven ECO Loop Label for use with Hanger Loop		1 ea	0.0	0

### Colorless BOM

Line Slot: Rapid Rivers II LS Shrt      State: Production      Season: F24  
 Merchandise Division: Sportswear      Merchandise Collection: Outdoor      Product Class: Woven Tops L/S  
 Designer: Sara.Allegre      Developer: cwestgate      LO Developer: raman.garg      Sourcing Manager: melissa.gallagher

Fit Engineer: alicehan

Design: F4MS155205      Sample LO:      Production LO: India

Style	Material Style	Style Description	Pattern	Base Size	Size Scale	Fit	SMU Type
AS7968	1552053	Rapid Rivers™ II Long Sleeve Shirt	M14S7113	2X	1X - 6X	Regular	N/A



Component	Details	Placement	Usage	Width	Marker Width
<b>SAP Material Code</b>					
Label 2	006564 33mm Care Content ECO Booklet Fold label with fully translated country of origin WHT/BLK for most, BLK/WHT for Titanium only, GRY/BLK is for Garment DYE ONLY		1 ea	0.0	0
Hangtag Package Part	121612 MSRP/UPC with RFID Specs for MSRP. Please refer to VAS specs for any exceptions. MSRP required on all product shipping to the US.		1 ea	0.0	0
Hangtag Package Part	097305 Columbia No Tech Hangtag		1 ea	0.0	0
Hangtag Package Part	126967 Regular Fit Swing Tag		1 ea	0.0	0
Packaging 1	064194 Outer Carton for costing purpose only		1 ea	0.0	0
Packaging 2	980001 Polybag See Standard CCS 4200 for specifications		1 ea	0.0	0
Packaging 3	980010 UPC Bag Sticker Generic (MHW/Columbia) See CCS4400/ 4401 and MHW4402 for Mt Hardwear for instructions		1 ea	0.0	0

This is confidential and proprietary information of Columbia Sportswear Company. You agree that you will not disclose this information to any third party or use it for any purpose other than on behalf of Columbia. You have no right to use Columbia's name or any of its trademarks, trade names, copyrights, patents, designs or other intellectual property except as set forth in writing by Columbia.

## Color Specification

Line Slot: Rapid Rivers II LS Shrt      State: Production      Season: F24  
 Merchandise Division: Sportswear      Merchandise Collection: Outdoor      Product Class: Woven Tops L/S  
 Designer: Sara.Allegre      Developer: cwestgate      LO Developer: raman.garg      Sourcing Manager: melissa.gallagher  
 Fit Engineer: alicehan



Design: F4MS155205      Sample LO:      Production LO: India  
 Style Material Style      Style Description      Pattern      Base Size      Size Scale      Fit      SMU Type  
 AS7968      1552053      Rapid Rivers™ II Long Sleeve Shirt      M14S7113      2X      1X - 6X      Regular      N/A

Component - Material	008-Black Everyday Gingham	396-Stone Green Oxford	434-Mtn Blue Everyday Gingham	471-Collegiate Navy Everyday Gingham	472-Collegiate Navy Everyday Gingham	482-Dark Mountain Oxford	681-Spice Oxford	699-Sail Red Everyday Gingham	861-Sunstone Everyday Gingham
Shell 1 - 108372	black	None	mountain blue	collegiate navy	collegiate navy2	None	None	sail red	sunstone
Alt Shell 1A - 121231	None	stone green	None	None	None	dark mountain	spice	None	None
Interfacing 1 - 011952	White	White	White	White	White	White	White	White	White
Button 1 - 097383	None	None	None	None	None	None	None	None	None
Button 2 - 097381									
Alt Button 1 - 098148	Dark Horn	Dark Horn	Light Horn	Dark Horn	Light Horn	Light Horn	Light Horn	Light Horn	Dark Horn
Alt Button 2 - 098146									
Label Logo 1 - 077256	Grill, Columbia Grey	Black, White	Columbia Grey, Grill	Columbia Grey, Grill	Columbia Grey, Grill	Columbia Grey, Grill	Grill, Columbia Grey	Black, White	Black, White
Thread 1 - 008214	White	Stone Green	White	White	Collegiate Navy	Dark Mountain	Spice	White	White
Thread 2 - 008214									
Webbing and Tape 1 - 033416	Black	Stone Green	Mountain Blue	Collegiate Navy	Collegiate Navy	Dark Mountain	Spice	Sail Red	Sunstone
Label 1 - 059200	White, Columbia Grey, Compass Blue	White, Columbia Grey, Compass Blue	White, Columbia Grey, Compass Blue	White, Columbia Grey, Compass Blue	White, Columbia Grey, Compass Blue	White, Columbia Grey, Compass Blue	White, Columbia Grey, Compass Blue	White, Columbia Grey, Compass Blue	White, Columbia Grey, Compass Blue
Label 2 - 006564	White, Black	White, Black	White, Black	White, Black	White, Black	White, Black	White, Black	White, Black	White, Black
Hangtag Package Part - 121612	Artwork	Artwork	Artwork	Artwork	Artwork	Artwork	Artwork	Artwork	Artwork
Hangtag Package Part - 097305									
Hangtag Package Part - 126967									
Packaging 3 - 980010	Stock	Stock	Stock	Stock	Stock	Stock	Stock	Stock	Stock
Packaging 1 - 064194									
Packaging 2 - 980001									

This is confidential and proprietary information of Columbia Sportswear Company. You agree that you will not disclose this information to any third party or use it for any purpose other than on behalf of Columbia. You have no right to use Columbia's name or any of its trademarks, trade names, copyrights, patents, designs or other intellectual property except as set forth in writing by Columbia.

### Costing BOM

Line Slot: Rapid Rivers II LS Shrt  
 Merchandise Division: Sportswear  
 Designer: Sara.Allegre  
 Fit Engineer: alicehan

Merchandise Collection: Outdoor  
 Developer: cwestgate

State: Production  
 Product Class: Woven Tops L/S  
 LO Developer: raman.garg

Season: F24  
 Sourcing Manager: melissa.gallagher



Design: F4MS155205  
 Style Material Style AS7968

Sample LO:  
 Style Description Pattern  
 Rapid Rivers™ II Long Sleeve Shirt M14S7113

Production LO: India  
 Base Size Size Scale  
 2X 1X - 6X

Fit SMU Type  
 Regular N/A

Colorway Number	Color Way	FOB Material	CIF Material	FOB Trim	CIF Trim	Allowance %	Total FOB	Total CIF
008	Black Everyday Gingham	5.196	0.000	11.057	0.000	0.0	16.253	0.000
396	Stone Green Oxford	5.626	0.000	11.057	0.000	0.0	16.683	0.000
434	Mtn Blue Everyday Gingham	5.196	0.000	11.057	0.000	0.0	16.253	0.000
471	Collegiate Navy Everyday Gingham	5.196	0.000	11.057	0.000	0.0	16.253	0.000
472	Collegiate Navy Everyday Gingham	5.196	0.000	11.057	0.000	0.0	16.253	0.000
482	Dark Mountain Oxford	5.626	0.000	11.057	0.000	0.0	16.683	0.000
681	Spice Oxford	5.626	0.000	11.057	0.000	0.0	16.683	0.000
699	Sail Red Everyday Gingham	5.196	0.000	11.057	0.000	0.0	16.253	0.000
861	Sunstone Everyday Gingham	5.196	0.000	11.057	0.000	0.0	16.253	0.000

### Costing BOM

Line Slot: Rapid Rivers II LS Shrt  
 Merchandise Division: Sportswear  
 Designer: Sara.Allegre  
 Fit Engineer: alicehan

Merchandise Collection: Outdoor  
 Developer: cwestgate

State: Production  
 Product Class: Woven Tops L/S  
 LO Developer: raman.garg

Season: F24  
 Sourcing Manager: melissa.gallagher



Design: F4MS155205  
 Style Material Style  
 AS7968 1552053

Sample LO:  
 Style Description Pattern  
 Rapid Rivers™ II M14S7113  
 Long Sleeve Shirt

Production LO: India  
 Base Size Size Scale Fit SMU Type  
 2X 1X - 6X Regular N/A

Component	Material	Description	Fabric Width	Supplier	Locked	Country of Origin	Managin g Liaison Office	UoM	Target Cost	FOB Unit Cost	CIF Unit Cost	Usage	Wastage %	Total FOB	Total CIF
Shell 1	108372	S21 M SW YD on 092290 AP 9387	56.0	Manju Exports	N	India	India	yd	0.0	2.25	0.0	2.211	3	5.124	0.000
Alt Shell 1A	121231	F23 M SW YD on 121321 (basketweave version of 092290) AP 11102	54.0	Manju Exports	N	India	India	yd	0.0	2.45	0.0	2.201	3	5.554	0.000
Interfacing 1	011952	Interlining Non-Woven Fusible Light Weight for Garment Wash	60.0	PCC asia LLC	Y	China	India	yd	0.0	0.38	0.0	0.185	3	0.072	0.000
Button 1	097383	20L DEBOSSSED COLUMBIA TWO TONE (LIKE 001601) LOW PROFILE Plastic BUTTON (SHAPE LIKE 056644)	0.0	BANGAL ORE SALES CORPORATION	Y	India	India	ea	0.0	0.0079	0.0	13.000	2.0	0.000	0.000



### Costing BOM

Line Slot: Rapid Rivers II LS Shrt  
 Merchandise Division: Sportswear  
 Designer: Sara.Allegre  
 Fit Engineer: alicehan

Merchandise Collection: Outdoor  
 Developer: cwestgate

State: Production  
 Product Class: Woven Tops L/S  
 LO Developer: raman.garg

Season: F24  
 Sourcing Manager: melissa.gallagher



Design: F4MS155205  
 Style: Material Style  
 AS7968 1552053

Sample LO:  
 Style Description Pattern  
 Rapid Rivers™ II M14S7113  
 Long Sleeve Shirt

Production LO: India  
 Base Size: 2X  
 Size Scale: 1X - 6X  
 Fit: Regular  
 SMU Type: N/A

Component	Material	Description	Fabric Width	Supplier	Locked	Country of Origin	Managin g Liaison Office	UoM	Target Cost	FOB Unit Cost	CIF Unit Cost	Usage	Wastage %	Total FOB	Total CIF
Alt Button 1	098148	20L DEBOSSSED COLUMBIA DARK HORN/LIGHT HORN (NO DTM) LOW PROFILE BUTTON (LIKE 056644)	0.0	BANGAL ORE SALES CORPOR ATION	Y	India	India	ea	0.0	0.0077	0.0	13.000	2.0	0.102	0.000
Button 2	097381	14L DEBOSSSED COLUMBIA TWO TONE (LIKE 001601) LOW PROFILE BUTTON (SHAPE LIKE 056644)	0.0	BANGAL ORE SALES CORPOR ATION	Y	India	India	ea	0.0	0.0079	0.0	2.000	2.0	0.000	0.000

### Costing BOM

Line Slot: Rapid Rivers II LS Shrt  
 Merchandise Division: Sportswear  
 Designer: Sara.Allegre  
 Fit Engineer: alicehan

Merchandise Collection: Outdoor  
 Developer: cwestgate

State: Production  
 Product Class: Woven Tops L/S  
 LO Developer: raman.garg

Season: F24  
 Sourcing Manager: melissa.gallagher



Design: F4MS155205  
 Style: Material Style  
 AS7968 1552053

Sample LO:  
 Style Description Pattern  
 Rapid Rivers™ II M14S7113  
 Long Sleeve Shirt

Production LO: India  
 Base Size: 2X  
 Size Scale: 1X - 6X  
 Fit: Regular  
 SMU Type: N/A

Component	Material	Description	Fabric Width	Supplier	Locked	Country of Origin	Managin g Liaison Office	UoM	Target Cost	FOB Unit Cost	CIF Unit Cost	Usage	Wastage %	Total FOB	Total CIF
Alt Button 2	098146	14L DEBOSSSED COLUMBIA DARK HORN/LIGHT HORN (NO DTM) LOW PROFILE BUTTON (LIKE 056644)	0.0	BANGAL ORE SALES CORPOR ATION	Y	India	India	ea	0.0	0.0073	0.0	2.000	2.0	0.015	0.000
Label Logo 1	077256	35mm Gem Columbia Flat Woven Label with starch	0.0	Avery Dennison Global	N	unassigne d	Portland	ea	0.0	0.02619	0.0	1.000	3.0	0.027	0.000
Thread 1	008214	Coats ASTRA Spun Polyester Tex 27 40/2	0.0	Coats Global Thread	N	unassigne d	Portland	meter	0.0	0.0003	0.0	213.000	5.0	0.067	0.000
Thread 2	008214	Coats ASTRA Spun Polyester Tex 27 40/2	0.0	Coats Global Thread	N	unassigne d	Portland	meter	0.0	0.0003	0.0	10.000	5.0	0.003	0.000

### Costing BOM

Line Slot: Rapid Rivers II LS Shrt  
 Merchandise Division: Sportswear  
 Designer: Sara.Allegre  
 Fit Engineer: alicehan

Merchandise Collection: Outdoor  
 Developer: cwestgate

State: Production  
 Product Class: Woven Tops L/S  
 LO Developer: raman.garg

Season: F24  
 Sourcing Manager: melissa.gallagher



Design: F4MS155205  
 Style Material Style  
 AS7968 1552053

Sample LO:  
 Style Description Pattern  
 Rapid Rivers™ II M14S7113  
 Long Sleeve Shirt

Production LO: India  
 Base Size Size Scale Fit SMU Type  
 2X 1X - 6X Regular N/A

Component	Material	Description	Fabric Width	Supplier	Locked	Country of Origin	Managing Liaison Office	UoM	Target Cost	FOB Unit Cost	CIF Unit Cost	Usage	Wastage %	Total FOB	Total CIF
Webbing and Tape 1	033416	3/8 in. Spun Poly Herringbone Tape 1 clr FOR SUN HOD Choose from Color Card	0.0	Naturub Group of Companies	Y	Bangladesh	India	yd	0.0	0.0513	0.0	0.083	7.0	10.662	0.000
Label 1	059200	40mm CSC International Size Extended Woven ECO Loop Label for use with Hanger Loop	0.0	Avery Dennison Global	N	China	Portland	ea	0.0	0.05956	0.0	1.000	3.0	0.061	0.000

### Costing BOM

Line Slot: Rapid Rivers II LS Shrt  
 Merchandise Division: Sportswear  
 Designer: Sara.Allegre  
 Fit Engineer: alicehan

Merchandise Collection: Outdoor  
 Developer: cwestgate

State: Production  
 Product Class: Woven Tops L/S  
 LO Developer: raman.garg

Season: F24  
 Sourcing Manager: melissa.gallagher



Design: F4MS155205  
 Style Material Style  
 AS7968 1552053

Sample LO:  
 Style Description Pattern  
 Rapid Rivers™ II M14S7113  
 Long Sleeve Shirt

Production LO: India  
 Base Size Size Scale Fit SMU Type  
 2X 1X - 6X Regular N/A

Component	Material	Description	Fabric Width	Supplier	Locked	Country of Origin	Managin g Liaison Office	UoM	Target Cost	FOB Unit Cost	CIF Unit Cost	Usage	Wastage %	Total FOB	Total CIF
Label 2	006564	33mm Care Content ECO Booklet Fold label with fully translated country of origin WHT/BLK for most, BLK/WHT for Titanium only, GRY/BLK is for Garment DYE ONLY	0.0	Avery Dennison Global	N	China	Portland	ea	0.0	0.01905	0.0	1.000	3.0	0.020	0.000
Hangtag Package Part	097305	Columbia No Tech Hangtag	0.0	Bao Shen (Apparel)	N	Vietnam	Portland	ea	0.0	0.014	0.0	1.000	0.0	0.014	0.000

### Costing BOM

Line Slot: Rapid Rivers II LS Shrt  
 Merchandise Division: Sportswear  
 Designer: Sara.Allegre  
 Fit Engineer: alicehan

Merchandise Collection: Outdoor  
 Developer: cwestgate

State: Production  
 Product Class: Woven Tops L/S  
 LO Developer: raman.garg

Season: F24  
 Sourcing Manager: melissa.gallagher



Design: F4MS155205  
 Style Material Style  
 AS7968 1552053

Sample LO:  
 Style Description Pattern  
 Rapid Rivers™ II M14S7113  
 Long Sleeve Shirt

Production LO: India  
 Base Size Size Scale Fit SMU Type  
 2X 1X - 6X Regular N/A

Component	Material	Description	Fabric Width	Supplier	Locked	Country of Origin	Managin g Liaison Office	UoM	Target Cost	FOB Unit Cost	CIF Unit Cost	Usage	Wastage %	Total FOB	Total CIF
Hangtag Package Part	121612	MSRP/UPC with RFID Specs for MSRP. Please refer to VAS specs for any exceptions. MSRP required on all product shipping to the US.	0.0	Avery Dennison Global	N	unassigne d	Portland	ea	0.0	0.04875	0.0	1.000	0.0	0.049	0.000
Hangtag Package Part	126967	Regular Fit Swing Tag	0.0	Hang Sang Press Co. Ltd	N	unassigne d	Portland	ea	0.0	0.023	0.0	1.000	0.0	0.023	0.000
Packaging 1	064194	Outer Carton for costing purpose only	0.0	Contracto r	N	unassigne d	Hong Kong	ea	0.0	0.0	0.0	1.000	3.0	0.000	0.000
Packaging 2	980001	Polybag See Standard CCS 4200 for specifications	0.0	Contracto r	N	unassigne d	Hong Kong	ea	0.0	0.0	0.0	1.000	3.0	0.000	0.000

### Costing BOM

Line Slot: Rapid Rivers II LS Shrt	State: Production	Season: F24
Merchandise Division: Sportswear	Merchandise Collection: Outdoor	Product Class: Woven Tops L/S
Designer: Sara.Allegre	Developer: cwestgate	LO Developer: raman.garg
Fit Engineer: alicehan		Sourcing Manager: melissa.gallagher
Design: F4MS155205	Sample LO:	Production LO: India
Style AS7968	Material Style 1552053	Style Description Pattern Rapid Rivers™ II Long Sleeve Shirt
	Base Size 2X	Size Scale 1X - 6X
	Fit Regular	SMU Type N/A



Component	Material	Description	Fabric Width	Supplier	Locked	Country of Origin	Managin g Liaison Office	UoM	Target Cost	FOB Unit Cost	CIF Unit Cost	Usage	Wastage %	Total FOB	Total CIF
Packaging 3	980010	UPC Bag Sticker Generic (MHW/Columbia) See CCS4400/ 4401 and MHW4402 for Mt Hardware for instructions	0.0	Avery Dennison Global	Y	China	Portland	ea	0.0	0.01323	0.0	1.000	5.0	0.014	0.000

### Costing BOM

Line Slot: Rapid Rivers II LS Shrt	State: Production	Season: F24
Merchandise Division: Sportswear	Merchandise Collection: Outdoor	Product Class: Woven Tops L/S
Designer: Sara.Allegre	Developer: cwestgate	LO Developer: raman.garg
Fit Engineer: alicehan		Sourcing Manager: melissa.gallagher
Design: F4MS155205	Sample LO:	Production LO: India
Style Material Style	Style Description Pattern	Base Size Size Scale
AS7968 1552053	Rapid Rivers™ II Long Sleeve Shirt M14S7113	2X 1X - 6X
		Fit SMU Type
		Regular N/A



This is confidential and proprietary information of Columbia Sportswear Company. You agree that you will not disclose this information to any third party or use it for any purpose other than on behalf of Columbia. You have no right to use Columbia's name or any of its trademarks, trade names, copyrights, patents, designs or other intellectual property except as set forth in writing by Columbia.





## Care Report

Line Slot: Rapid Rivers II LS Shrt	State: Production	Season: F24
Merchandise Division: Sportswear	Merchandise Collection: Outdoor	Product Class: Woven Tops L/S
Designer: Sara.Allegre	Developer: cwestgate	LO Developer: raman.garg
Fit Engineer: alicehan		Sourcing Manager: melissa.gallagher
Design: F4MS155205	Sample LO:	Production LO: India
Style AS7968	Material Style 1552053	Style Description Pattern Rapid Rivers™ II Long Sleeve Shirt
	Base Size 2X	Size Scale 1X - 6X
	Fit Regular	SMU Type N/A



Care Code: 1080		Color Way Number	Color Way Name
<b>English</b>	Machine Wash Cold Gentle, With Like Colors, Non-Chlorine Bleach When Needed, Tumble Dry Low, Remove Promptly, Iron Medium, If Present Do Not Iron Decal, Drycleanable	008	Black Everyday Gingham
<b>French</b>	Lavage machine à froid, Cycle délicat, Avec des couleurs similaires, Blanchir sans chlore si besoin, Séchage machine, basse température, Sortir immédiatement de la machine, Repasser à température moyenne, Le cas échéant, ne pas repasser la décalcomanie, Nettoyable à sec	396	Stone Green Oxford
<b>German</b>	Schonwaschgang mit kaltem Wasser, Mit gleichen Farben, Nach Bedarf chlorfreies Bleichmittel verwenden, Trocknen im Wäschetrockner bei niedriger Temperatur, Sofort aus dem Trockner nehmen, Bügeln mit mittlerer Temperatur, Falls vorhanden, Dekorbild nicht bügeln, Reinigungsfähig	434	Mtn Blue Everyday Gingham
<b>Portuguese</b>	Lavar à maquina com água fria, ciclo para roupas delicadas, Com cores similares, Alvejar sem cloro quando necessário, Secar à máquina em temperatura baixa, Remover prontamente, Passar a ferro em temperatura média, Se presente, não passar o ferro sobre o decalque, Lavável a seco	471	Collegiate Navy Everyday Gingham
<b>Spanish</b>	Lavar a maquina con agua fría, en ciclo delicado, Lavar con colores similares, Use lejía sin cloro cuando sea necesario, Usar secadora a temperatura baja, Retirar inmediatamente, Planchar a temperatura media, En su caso, no planche la pegatina, Lavable en seco	472	Collegiate Navy Everyday Gingham
<b>Italian</b>	Lavare in lavatrice in acqua fredda, ciclo delicato, Con colori simili, Solo candeggina senza cloro se necessario, Asciugare a tamburo a bassa temperatura, Rimuovere tempestivamente, Stirare con ferro a temperatura media, Se presente, non stirare la decalcomania, Lavabile a secco	482	Dark Mountain Oxford
<b>Russian</b>	Щадящая машинная стирка в холодной воде, Стирать с изделиями подобного цвета, Отбеливать без хлора, Сушить при низкой температуре, Сразу убрать из сушилки, Гладить при средней температуре, Если есть, не гладить наклейки и роспись на текстиле, Химчистка допускается	681	Spice Oxford
<b>Czech Republican</b>	Praní v pračce při nízké teplotě, jemný cyklus, S podobnými barvami, V případě potřeby bělit bez chlóru, Sušení v sušičce, nízká teplota, Ihned odepnout, Žehlení při střední teplotě, Nežehlit obtisky, jsou-li přítomny, Vhodné k chemickému čištění	699	Sail Red Everyday Gingham
<b>Hebrew</b>	כביסה במכונה במים קרים, כביסה עדינה, עם צבעים דומים, מלבין ללא כלור, בעת הצורך, לייבש במייבש כביסה בחום נמוך, להסיר מיד, ללהיץ בחום בינוני, אם ישנה, לא להיץ את מדבקת הדקאל, ניתן לנקות בניקוי יבש	861	Sunstone Everyday Gingham
<b>Hungarian</b>	Géppel mossa, hideg vízzel, kímélő programmal, Hasonló színűekkel, Szükség esetén klórmentes fehéritőt használjon, Szárítógépben alacsony hőfokon szárítsa, Mosás után azonnal vegye ki a gépből, Közepes hőfokon vasalja, Ha van az anyagon matrica, azt ne vasalja, Vegytisztítható		
<b>Polish</b>	Prać w temperaturze nie przekraczającej 30°C, cykl delikatny, Prać z podobnymi kolorami, Wybielać niechlorowym wybielaczem w razie potrzeb, Można suszyć bębnowo, niska temperatura, Natychmiast usunąć, Prasować w temperaturze do 150°C, Nie prasować ozdób, jeśli są obecne, Można czyścić chemicznie		
<b>Portuguese Brazil</b>	Lavar à maquina com água fria, ciclo para roupas delicadas, Com cores similares, Alvejar sem cloro quando necessário, Secar em tambor rotativo em temperatura baixa, Remover prontamente, Passar a ferro em temperatura média, Se presente, não passar o ferro sobre o decalque, Lavável a seco		
<b>Slovakian</b>	Perte v pračce v studenej vode, šetriaci program, Spolu len podobné farby, V prípade potreby použite odfarbovací prostriedok bez obsahu chlóru, Sušte v bubnovej sušičke pri nízkych otáčkach, Okamžite odstráňte, Žehlíte mierne teplou žehličkou, Ak má štítok, nežehlíte ho, Môže sa čistiť chemicky		
<b>Slovenian</b>	Nežno mrzlo strojno pranje, Z podobnimi barvami, Belite brez klora po potrebi, Nizko strojno sušenje, Odstraniti takoj, Srednje likanje, Če obstaja, ne likati nalepk, Za suho čiščenje		
<b>Spanish Latin American</b>	Lavar a maquina con agua fría, en ciclo delicado, Lavar con colores similares, Usar blanqueador sin cloro cuando sea necesario, Usar secadora a temperatura baja, Retirar inmediatamente, Planchar a temperatura media, En su caso, no planche el diseño impreso, Lavable en seco		
<b>Turkish</b>	Makinada Yıkanır, Soğuk, Narin Program, Aynı Renklerle Yıkayın, Gerekirse Klor İçermeyen Ağartıcı Kullanın, Tambur Kurutma, Düşük, Hemen Çıkarın, Orta Isıda Ütöleyin, Varsa Çıkartmayı Ütölemeyin, Kuru Temizleme Yapılır		
<b>Chinese Simplified</b>	冷水慢循环机洗, 可与相近色同洗, 在必要时进行非氯漂白, 低温滚筒烘干, 及时拆除, 中温熨烫, 如有, 请勿熨烫贴花, 可干洗		



## Content Report

Line Slot: Rapid Rivers II LS Shrt	State: Production	Season: F24
Merchandise Division: Sportswear	Merchandise Collection: Outdoor	Product Class: Woven Tops L/S
Designer: Sara.Allegre	Developer: cwestgate	LO Developer: raman.garg
Fit Engineer: alicehan		Sourcing Manager: melissa.gallagher
Design: F4MS155205	Sample LO:	Production LO: India
Style AS7968	Material Style: 1552053	Style Description: Rapid Rivers™ II Long Sleeve Shirt
	Pattern: M14S7113	Base Size: 2X
		Size Scale: 1X - 6X
		Fit: Regular
		SMU Type: N/A



CONTENT CODE: BGD			Color Way Number	Color Way Name
Shell: 97% Cotton, 3% Elastane Exclusive of Trimming				
FRENCH	Extérieur:	97% Coton, 3% Élasthanne Sauf les bordures	008	Black Everyday Gingham
GERMAN	Außenhülle:	97% Baumwolle, 3% Elastan Ohne Besatz		
PORTUGUESE	Exterior:	97% Algodão, 3% Elastano Sem orlas	471	Collegiate Navy Everyday Gingham
SPANISH	Cubierta:	97% Algodón, 3% Elastano Exclusivo de los ribetes		
ITALIAN	Guscio esterno:	97% Cotone, 3% Elastan Ad eccezione dei bordini		
RUSSIAN	Оболочка:	97% Хлопок, 3% Эластан Без дополнительных деталей	699	Sail Red Everyday Gingham
CZECH REPUBLICAN	Skořepina:	97% Bavlna, 3% Elastan Bez nášivek		
HEBREW		מעטפת חיצונית: 97% כותנה, 3% אלסטן ללא קישוט		
HUNGARIAN	Külső:	97% Pamut, 3% Elasztán Szegélydíszen kívül	434	Mtn Blue Everyday Gingham
POLISH	Powłoka:	97% Bawełna, 3% Elastan Wyłączając naszywki		
PORTUGUESE BRAZIL	Exterior:	97% Algodão, 3% Elastano Sem adornos	472	Collegiate Navy Everyday Gingham
SLOVAKIAN	Plášť:	97% Bavlna, 3% Elastan Okrem lemovania		
SLOVENIAN	Lupina:	97% Bombaž, 3% Elastan Brez obrezovanja		
SPANISH LATIN AMERICAN	Cubierta:	97% Algodón, 3% Elastano Exclusivo de los ribetes	482	Dark Mountain Oxford
TURKISH	Kabuk:	97% Pamuk, 3% Elastan Süsler Hariç		
CHINESE SIMPLIFIED	外壳:	97% 棉, 3% 弹性 不包括装饰品	861	Sunstone Everyday Gingham
CHINESE TRADITIONAL	外殼:	97% 棉, 3% 彈性 不包括裝飾品		
JAPANESE	シエル:	97% 綿, 3% エラストイン 装飾品を除く	681	Spice Oxford
KOREAN	:	97% , 3%	396	Stone Green Oxford
DANISH	Skal:	97% Bomuld, 3% Elastan Inkluderer ikke kant		
NORWEGIAN	Skall:	97% Bomull, 3% Elastan Eksklusiv trimming		
SWEDISH	Ytterdel:	97% Bomull, 3% Elastan Utan trimming		
DUTCH	Schelp:	97% Katoen, 3% Elastaan Exclusief trimmen		
FRENCH CANADIAN	Extérieur:	97% Coton, 3% Élasthanne Exclut les bordures		

### Pattern Piece Detail

Line Slot: Rapid Rivers II LS Shrt      State: Production      Season: F24  
 Merchandise Division: Sportswear      Merchandise Collection: Outdoor      Product Class: Woven Tops L/S  
 Designer: Sara.Allegre      Developer: cwestgate      LO Developer: raman.garg      Sourcing Manager: melissa.gallagher  
 Fit Engineer: alicehan



Design: F4MS155205      Sample LO:      Production LO: India

Style	Material Style	Style Description	Pattern	Base Size	Size Scale	Fit	SMU Type
AS7968	1552053	Rapid Rivers™ II Long Sleeve Shirt	M14S7113	2X	1X - 6X	Regular	N/A

#### M14S7113 - AS7968

Component	Quantity	Long Description	Abbreviation	Code
Shell 1	1	BACK	BK	20001
Shell 1	1	LEFT FRONT	LTFT	14001
Shell 1	1	LEFT PATCH POCKET	LTPCPKT	74030
Shell 1	1	LEFT SLEEVE	LTSLV	34001
Shell 1	1	LOWER TOP COLLAR	LWTPCLR	43002
Shell 1	1	LOWER UNDER COLLAR	LWUNCLR	43001
Shell 1	1	RIGHT FRONT	RTFT	16001
Shell 1	1	RIGHT SLEEVE	RTSLV	36001
Shell 1	1	TOP BACK YOKE	TPBKYK	20005
Shell 1	1	TOP COLLAR	TPCLR	40002
Shell 1	2	TOP CUFF	TPCUF	80002
Shell 1	2	TOP SLEEVE PLACKET	TPSLVPLKT	90016
Shell 1	1	UNDER BACK YOKE	UNBKYK	20006
Shell 1	1	UNDER COLLAR	UNCLR	40003
Shell 1	2	UNDER CUFF	UNCUF	80003
Shell 1	2	UNDER SLEEVE PLACKET	UNSLVPLKT	90017
Interfacing 1	1	LEFT PLACKET PELLON	LTPLKTPEL	94004
Interfacing 1	1	LOWER TOP COLLAR	LWTPCLR	43002
Interfacing 1	1	RIGHT PLACKET PELLON	RTPLKTPEL	96004
Interfacing 1	1	TOP COLLAR	TPCLR	40002
Interfacing 1	2	TOP CUFF	TPCUF	80002

This is confidential and proprietary information of Columbia Sportswear Company. You agree that you will not disclose this information to any third party or use it for any purpose other than on behalf of Columbia. You have no right to use Columbia's name or any of its trademarks, trade

### Pattern Piece Detail

Line Slot: Rapid Rivers II LS Shrt      State: Production      Season: F24  
 Merchandise Division: Sportswear      Merchandise Collection: Outdoor      Product Class: Woven Tops L/S  
 Designer: Sara.Allegre      Developer: cwestgate      LO Developer: raman.garg      Sourcing Manager: melissa.gallagher  
 Fit Engineer: alicehan

Design: F4MS155205      Sample LO:      Production LO: India

Style	Material Style	Style Description	Pattern	Base Size	Size Scale	Fit	SMU Type
AS7968	1552053	Rapid Rivers™ II Long Sleeve Shirt	M14S7113	2X	1X - 6X	Regular	N/A



names, copyrights, patents, designs or other intellectual property except as set forth in writing by Columbia.

### Measurements

Line Slot: Rapid Rivers II LS Shrt  
 Merchandise Division: Sportswear  
 Designer: Sara.Allegre  
 Fit Engineer: alicehan

Merchandise Collection: Outdoor  
 Developer: cwestgate

State: Production  
 Product Class: Woven Tops L/S  
 LO Developer: raman.garg

Season: F24  
 Sourcing Manager: melissa.gallagher



Design: F4MS155205  
 Style AS7968  
 Material Style 1552053

Sample LO:  
 Style Description Pattern  
 Rapid Rivers™ II M14S7113  
 Long Sleeve Shirt

Production LO: India  
 Base Size 2X  
 Size Scale 1X - 6X

Fit Regular  
 SMU Type N/A

Sort Order		Use	Type	Placemen t	(+/-)	1X	2X	3X	4X	5X	6X
Grade Rule: CSC Mens Woven Tops - Supersize - 1X-6X (2X) - Block: null											
1101.0	CHEST WIDTH - circumference - 1 inch down from armhole seam	QC	Graded		0.75	53.0	<b>56.0</b>	60.0	64.0	68.0	72.0
1300.0	WAIST WIDTH POSITION - from HPS		Graded		0.0	19.625	<b>20.0</b>	20.375	20.75	21.125	21.5
1400.0	WAIST WIDTH - circumference	QC	Graded		0.75	53.0	<b>56.0</b>	60.0	64.0	68.0	72.0
1610.0	SWEEP WIDTH - circumference	QC	Graded		0.75	53.0	<b>56.0</b>	60.0	64.0	68.0	72.0
2000.0	BACK BODY LENGTH - HPS to edge of hem	QC	Graded		0.5	32.375	<b>33.0</b>	33.625	34.25	34.875	35.5
2203.0	SHOULDER WIDTH - Natural Shoulder - seam to seam	QC	Graded		0.375	21.5	<b>22.5</b>	23.5	24.5	25.5	26.5
2402.0	BACK YOKE HEIGHT - from CB neck seam		Graded		0.125	4.75	<b>4.875</b>	5.0	5.125	5.25	5.375
2602.0	SLEEVE LENGTH - Long Sleeve - CB neck to hem edge	QC	Graded		0.5	37.0	<b>38.0</b>	38.75	39.5	40.25	41.0
2722.0	SLEEVE WIDTH - circumference - 1 inch down from armhole seam	QC	Graded		0.375	21.75	<b>22.5</b>	23.5	24.5	25.5	26.5
2822.0	ELBOW WIDTH - circumference - at mid point of under sleeve seam	QC	Graded		0.25	16.0	<b>16.5</b>	17.125	17.75	18.375	19.0
3000.0	SLEEVE OPENING - long sleeve - circumference	QC	Graded		0.25	10.5	<b>10.75</b>	11.0	11.25	11.5	11.75
3200.0	CUFF HEIGHT	QC	Graded		0.125	2.25	<b>2.25</b>	2.25	2.25	2.25	2.25
3360.0	SLEEVE PLACKET LENGTH		Graded		0.125	7.0	<b>7.0</b>	7.0	7.0	7.0	7.0
3361.0	SLEEVE PLACKET WIDTH		Graded		0.125	1.0	<b>1.0</b>	1.0	1.0	1.0	1.0
3450.0	NECK CIRCUMFERENCE - at seam	QC	Graded		0.25	20.0	<b>21.0</b>	22.0	23.0	24.0	25.0

### Measurements

Line Slot: Rapid Rivers II LS Shrt	State: Production	Season: F24
Merchandise Division: Sportswear	Merchandise Collection: Outdoor	Product Class: Woven Tops L/S
Designer: Sara.Allegre	Developer: cwestgate	LO Developer: raman.garg
Fit Engineer: alicehan		Sourcing Manager: melissa.gallagher
Design: F4MS155205	Sample LO:	Production LO: India
Style Material Style	Style Description Pattern	Base Size Size Scale
AS7968 1552053	Rapid Rivers™ II Long Sleeve Shirt M14S7113	2X 1X - 6X
		Fit SMU Type
		Regular N/A



Sort Order	Use	Type	Placemen t	(+/-)	1X	2X	3X	4X	5X	6X
3591.0	CENTER FRONT PLACKET WIDTH		Graded		0.125	1.25	<b>1.25</b>	1.25	1.25	1.25
3600.0	COLLAR LENGTH - at top	QC	Graded		0.25	20.5	<b>21.5</b>	22.5	23.5	24.5
3650.0	COLLAR HEIGHT - at CB	QC	Graded		0.125	1.875	<b>1.875</b>	1.875	1.875	1.875
3653.0	COLLAR STAND HEIGHT - at CB		Graded		0.125	1.25	<b>1.25</b>	1.25	1.25	1.25
3680.0	COLLAR POINT LENGTH		Graded		0.125	2.25	<b>2.25</b>	2.25	2.25	2.25
6501.0	CHEST POCKET WIDTH		Varies By Style		0.125	5.0	<b>5.25</b>	5.25	5.5	6.0
6502.0	CHEST POCKET HEIGHT		Varies By Style		0.125	5.75	<b>6.0</b>	6.0	6.25	6.5
3190.0	Webbing and Tape 1		Component		0.0	3.0	<b>3.0</b>	3.0	3.0	3.0

This is confidential and proprietary information of Columbia Sportswear Company. You agree that you will not disclose this information to any third party or use it for any purpose other than on behalf of Columbia. You have no right to use Columbia's name or any of its trademarks, trade names, copyrights, patents, designs or other intellectual property except as set forth in writing by Columbia.

## Technical

Line Slot: Rapid Rivers II LS Shrt		State: Production		Season: F24			
Merchandise Division: Sportswear	Merchandise Collection: Outdoor	Product Class: Woven Tops L/S					
Designer: Sara.Allegre	Developer: cwestgate	LO Developer: raman.garg	Sourcing Manager: melissa.gallagher				
Fit Engineer: alicehan							
Design: F4MS155205	Sample LO:	Production LO:	India				
Style AS7968	Material Style 1552053	Style Description Rapid Rivers™ II Long Sleeve Shirt	Pattern M14S7113	Base Size 2X	Size Scale 1X - 6X	Fit Regular	SMU Type N/A



La

All topstitching  
ISO 301 1/4" from edge  
unless otherwise noted

Interfacing 1  
-CF Placket  
-Collar  
-Collar stand  
-Sleeve cuffs

Thread 1  
\* All DTM Topstitching  
Thread 2  
\* DTM all other construction

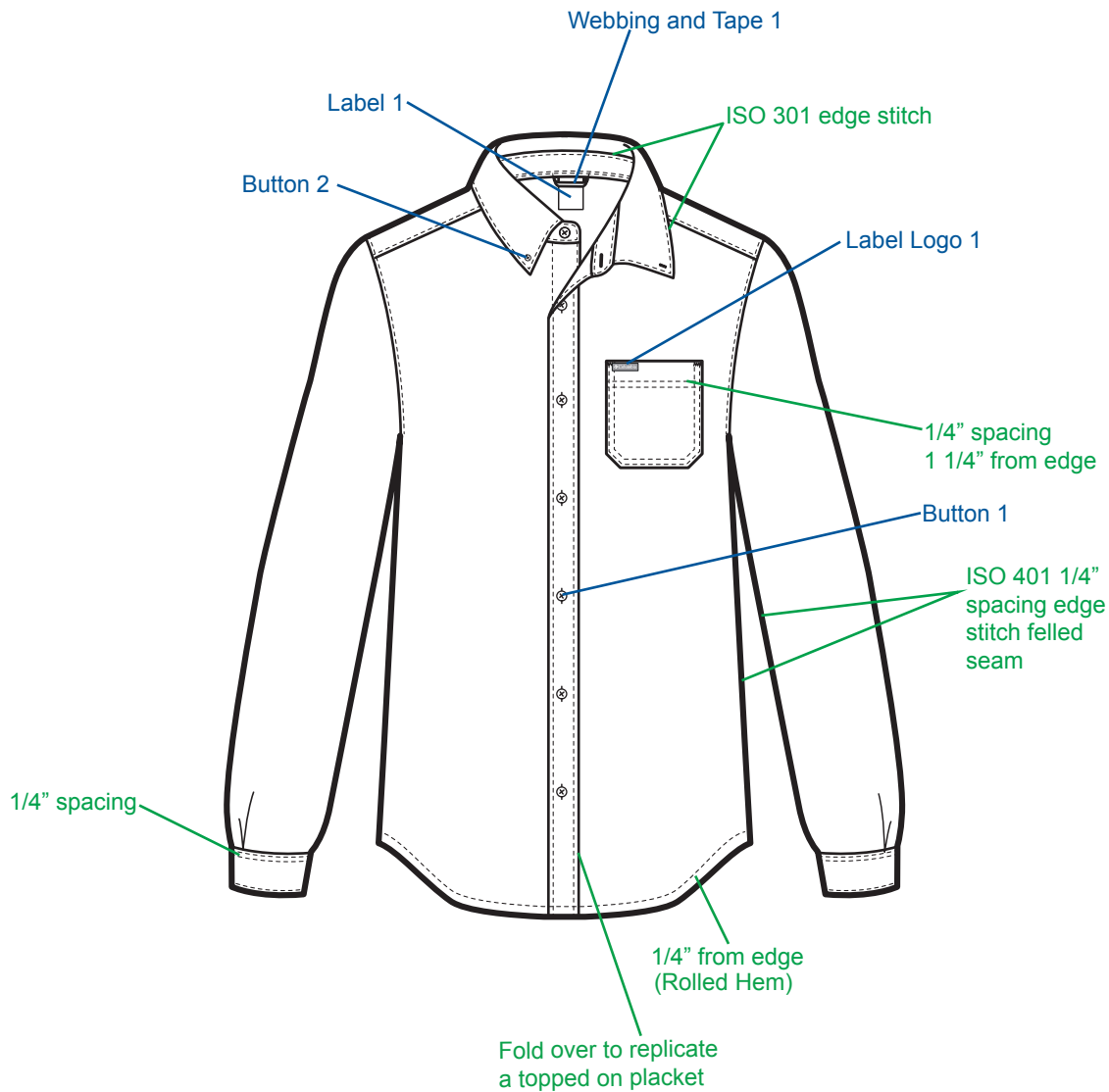



## Technical

Line Slot: Rapid Rivers II LS Shrt      State: Production      Season: F24  
 Merchandise Division: Sportswear      Merchandise Collection: Outdoor      Product Class: Woven Tops L/S  
 Designer: Sara.Allegre      Developer: cwestgate      LO Developer: raman.garg      Sourcing Manager: melissa.gallagher  
 Fit Engineer: alicehan

Design:	F4MS155205	Sample LO:	Production LO:	India			
Style	Material Style	Style Description	Pattern	Base Size	Size Scale	Fit	SMU Type
AS7968	1552053	Rapid Rivers™ II Long Sleeve Shirt	M14S7113	2X	1X - 6X	Regular	N/A

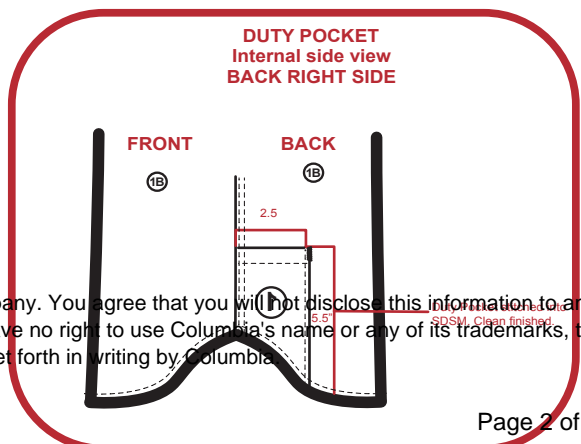
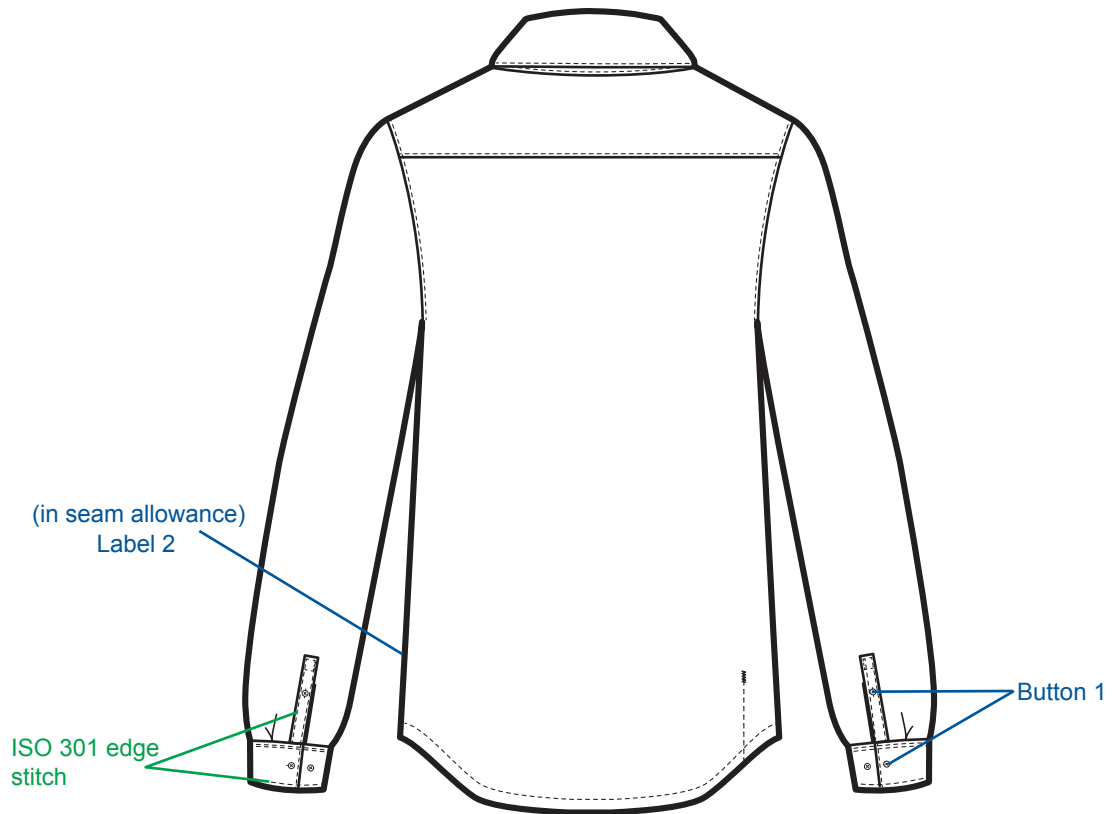

This is confidential and proprietary information of Columbia Sportswear Company. You agree that you will not disclose this information to any third party or use it for any purpose other than on behalf of Columbia. You have no right to use Columbia's name or any of its trademarks, trade names, copyrights, patents, designs or other intellectual property except as set forth in writing by Columbia.

### Detail Sketch

Line Slot: Rapid Rivers II LS Shrt  
 Merchandise Division: Sportswear  
 Designer: Sara.Allegre  
 Merchandise Collection: Outdoor  
 Developer: cwestgate  
 State: Production  
 Product Class: Woven Tops L/S  
 LO Developer: raman.garg  
 Season: F24  
 Sourcing Manager: melissa.gallagher

Fit Engineer: alicehan

Design:	F4MS155205	Sample LO:	Production LO:	India			
Style	Material Style	Style Description	Pattern	Base Size	Size Scale	Fit	SMU Type
AS7968	1552053	Rapid Rivers™ II Long Sleeve Shirt	M14S7113	2X	1X - 6X	Regular	N/A

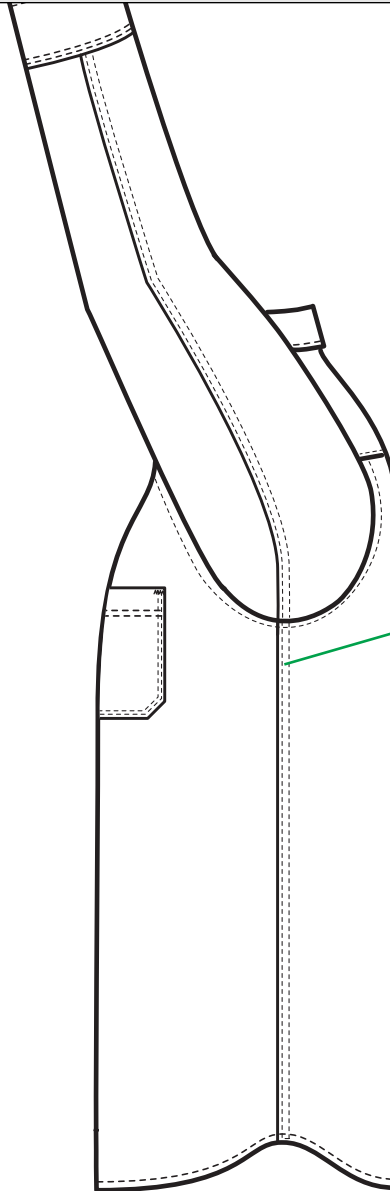

Flat Felled Seam

### Detail Sketch

Line Slot: Rapid Rivers II LS Shrt      State: Production      Season: F24  
 Merchandise Division: Sportswear      Merchandise Collection: Outdoor      Product Class: Woven Tops L/S  
 Designer: Sara.Allegre      Developer: cwestgate      LO Developer: raman.garg      Sourcing Manager: melissa.gallagher  
 Fit Engineer: alicehan

Design: F4MS155205      Sample LO:      Production LO: India

Style	Material Style	Style Description	Pattern	Base Size	Size Scale	Fit	SMU Type
AS7968	1552053	Rapid Rivers™ II Long Sleeve Shirt	M14S7113	2X	1X - 6X	Regular	N/A



Last U

### DETAIL SKETCH sleeve cuff & placket

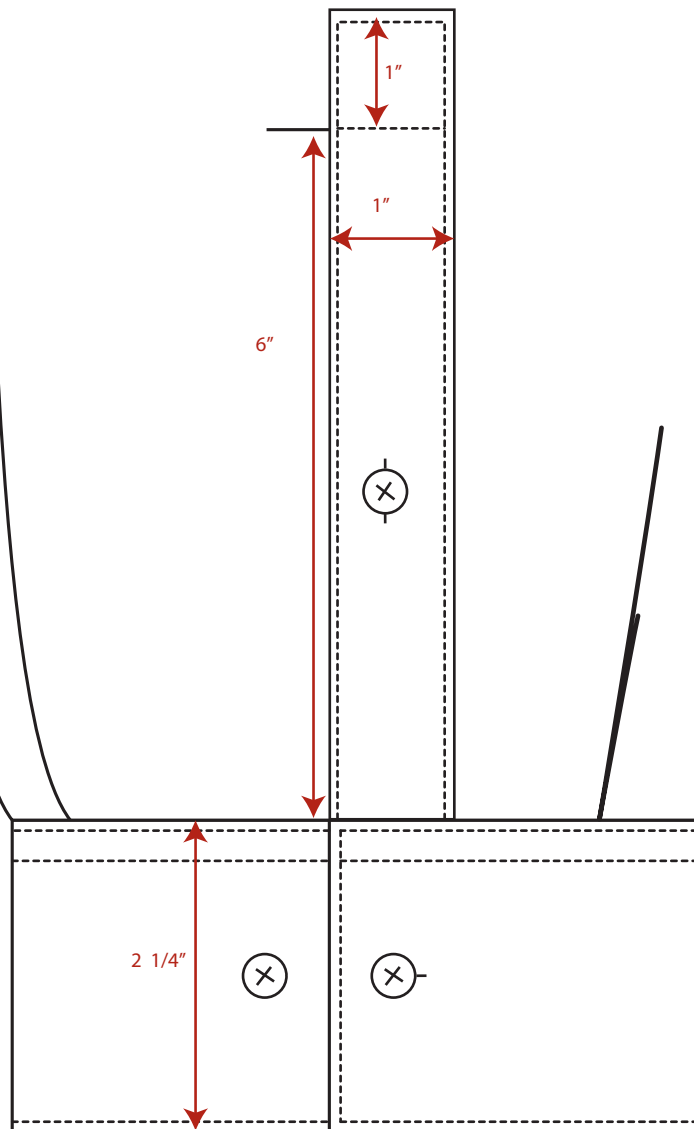

### Detail Sketch

Line Slot: Rapid Rivers II LS Shrt		State: Production		Season: F24			
Merchandise Division: Sportswear		Merchandise Collection: Outdoor		Product Class: Woven Tops L/S			
Designer: Sara.Allegre		Developer: cwestgate		LO Developer: raman.garg		Sourcing Manager: melissa.gallagher	
Fit Engineer: alicehan							
Design: F4MS155205		Sample LO:		Production LO: India			
Style	Material Style	Style Description	Pattern	Base Size	Size Scale	Fit	SMU Type
AS7968	1552053	Rapid Rivers™ II Long Sleeve Shirt	M14S7113	2X	1X - 6X	Regular	N/A



### DETAIL SKETCH Pocket placement

2" CF to pocket edge  
(FOR SIZE MEDIUM - MAY ADJUST POSITION FROM CF FOR OTHER SIZES DUE TO AH PLACEMENT)

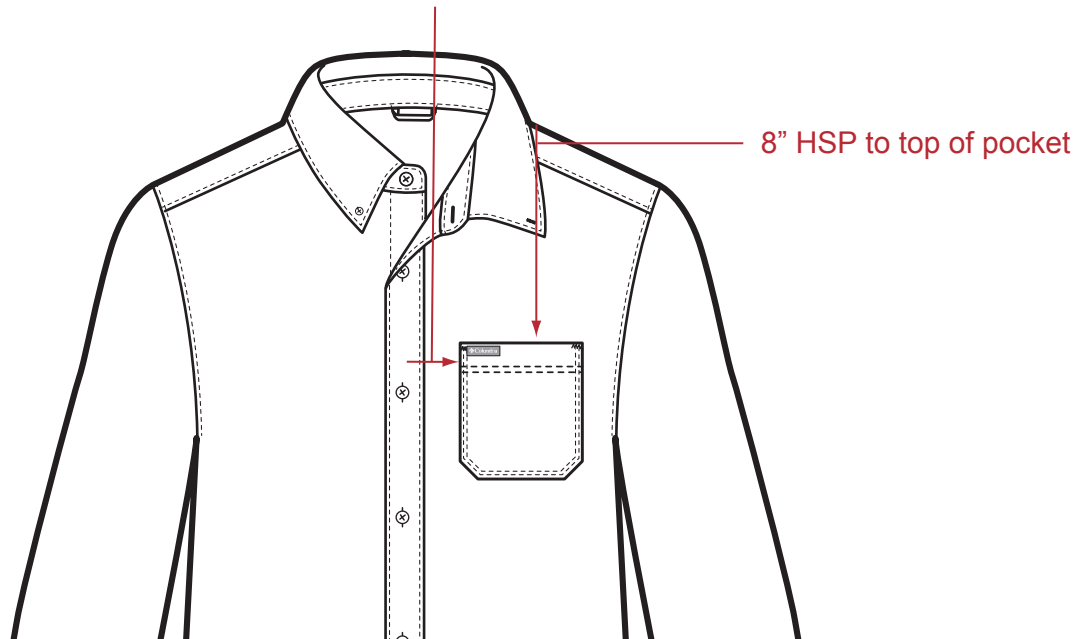

This is confidential and proprietary information of Columbia Sportswear Company. You agree that you will not disclose this information to any third party or use it for any purpose other than on behalf of Columbia. You have no right to use Columbia's name or any of its trademarks, trade names, copyrights, patents, designs or other intellectual property except as set forth in writing by Columbia.

# Hangtag Package Report

Apparel Style: AS7968

Season: F24

Brand: Columbia

Merchandise Category: Sportswear

Merchandiser: Lee.Braxton

Line Slot: Rapid Rivers II LS Shrt

Sort Order: 0.5 Part: 126967 - Regular Fit Swing Tag  
 Instruction: Swing tag to be placed on top of cover tag on same plastic loop.

Sort Order: 1.0 Part: 097305 - Columbia No Tech Hangtag  
 Instruction: "(FOR TOPS W/CF BUTTONS)  
 HANG TAG TO BE PLACED ON 5" CIRCULAR SWIFT TACK AT 2ND  
 BUTTON HOLE FROM TOP (OMNI-TECH, OMNI-SHADE, OMNI-SHIELD)"

Sort Order: 9.0 Part: 121612 - MSRP/UPC with RFID Specs for MSRP.  
 Please refer to VAS specs for any exceptions. MSRP required on all product shipping to the US.  
 Instruction:

SKU Reference #	Item	Name	Revised Date
OP984553	097305	OP984553_097305_TC_Columbia_No Tech	09-26-22

TECH CARD (Front)



TECH CARD (Back)



SKU Code	Item	Supplier #	Columbia
Process Blue / Process Blue	32pt C15		Columbia 100% POLYESTER 100% POLYESTER 100% POLYESTER
2.31" x 3.44" / 58.58mm x 86.35mm	Agapour Coating Die Cut, Zero Punch	TC-1	

SKU Reference #	Item	Name	Revised Date
n/a	121612	PDM_121612_RFID UPC Sticker_Dec_3_2022	12-03-22



SKU Code	Item	Supplier #	Columbia
Black	White, Dual Matrix Sticker Stock		Columbia 100% POLYESTER 100% POLYESTER 100% POLYESTER
1.585" x 1.641" / 39.95mm x 41.67mm	Direct, Adhesive in Perforated Sheet up from bottom 1/8"	UPC-5	